

Designing medical devices for isolation and safety

OPTOCOUPLERS, ALONG WITH SOUND DESIGN PRACTICES, PROVIDE EFFECTIVE ISOLATION FOR MEDICAL EQUIPMENT AND PROTECT PATIENTS FROM POTENTIALLY DANGEROUS LEAKAGE CURRENTS.

The use of ac-line-powered medical diagnostic, measurement, and treatment equipment potentially exposes patients and even caregivers to the risk of electrical shock, burns, internal-organ damage, and cardiac arrhythmias directly due to leakage current resulting from improper grounding and

electrical isolation. The electrical conductivity of body fluids and the presence of various conductive solutions and gels in the patient care make the treatment environment even more potentially dangerous. The use of gels substantially reduces the normally high resistance of the skin—greater than 50Ω. A second significant hazard results from potential electrical emissions among the diagnostic and treatment devices, which can degrade the performance of other nearby medical devices. As a result, many regulations from agencies ranging from the US FDA (Food and Drug Administration), the EU (European Union), and other safety and regulatory bodies ensure that these medical devices comply with the safety standards.

Standard IEC (International Electrotechnical Commission) 60601-1 defines medical-equipment electrical-safety conditions necessary to protect patients, operators, and the surroundings. Other standards define more than just safety requirements. For example, the IEC 60601-1-x collateral-standard series deals with issues such as EMC (electromagnetic compatibility), X-ray protection, and programmable electrical medical systems. EMC is indeed an important criterion for medical equipment because the equipment cannot be a source of EMI (electromagnetic interference), which could pre-

vent accurate operation of other medical equipment and must be immune to potential EMI in the operating environment. Since November 2005, medical equipment has had to comply with the updated IEC 60601-1-2:2001 EMC standard.

In the portions of the medical equipment transmitting digital data, designers can isolate sensitive circuitry or patients

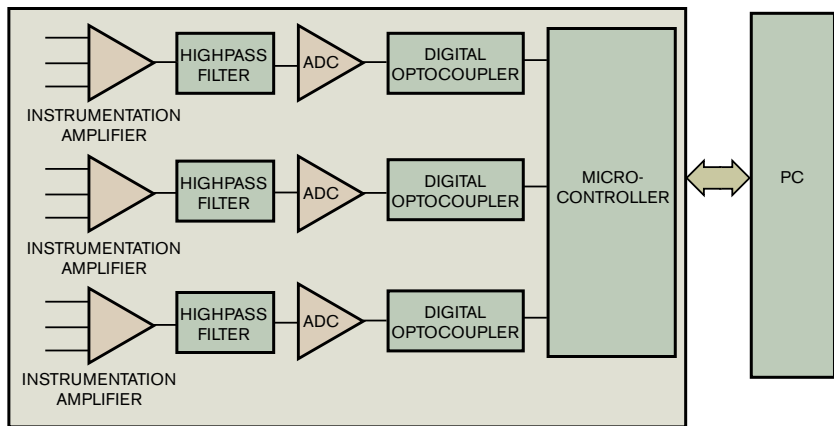

Figure 1 A front-end module in an ECG machine indicates the use of galvanic isolation devices, or optocouplers, to isolate patient electrodes from the machine's electronics.

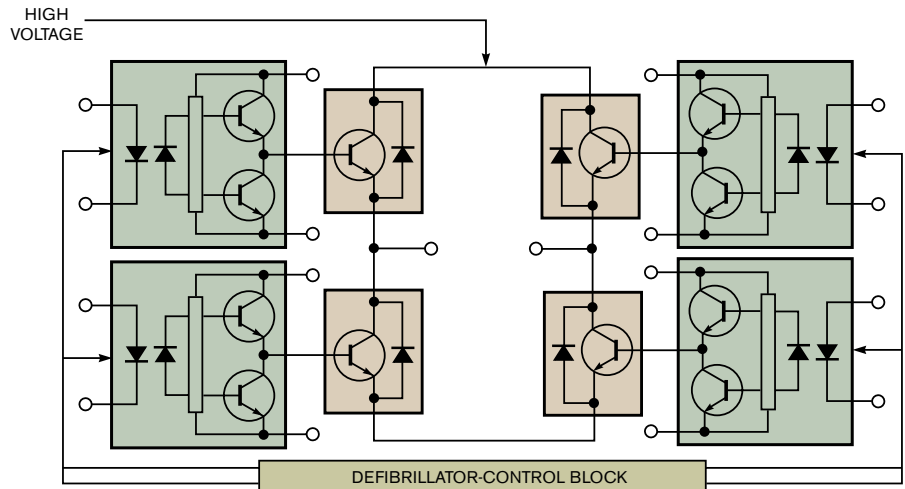

Figure 2 A defibrillator device uses optical isolation to separate the high-voltage-pulse section from the device's low-voltage control electronics.

from high-voltage environments using optocoupler- or transformer-based approaches. Optocoupler-based techniques have in the past been able to support only limited data rates, which led to the use of transformer-based isolation. This approach provided the requisite data rates but generally required more components taking up more space on a PCB (printed-circuit board) and a more complex design. This situation has changed with the introduction of optocouplers capable of higher data rates and improved timing characteristics.

REINFORCED GALVANIC ISOLATION

Unlike functional isolation, reinforced isolation both protects from electric shock and ensures that a design is fail-safe—a mode of system termination that automatically leaves system processes and components in a secure state when a failure occurs or when a system detects a failure (Reference 1). This feature is critical for medical equipment, such as an ECG (electrocardiograph) system or a defibrillator (figures 1 and 2, respectively). Optocouplers providing reinforced isolation are certified under IEC/EN/DIN (Deutsches Institut für Normung) EN 60747-5-2, which is an international standard for optically isolated semiconductor components.

To meet the IEC-60601-1 medical standards' insulation requirements, optocouplers must have UL (Underwriters Laboratories) 1577 or IEC 60747-5-2 certification and must meet component-creepage, external-clearance, and test-voltage requirements depending on the insulation level of the interface. The certification defines creepage distance as the shortest surface path over a solid dielectric between two galvanically isolated conductors. The external-clearance distance is the shortest distance through air, or “line-of-sight” distance, between two galvanically isolated conductors.

When operating at working voltages higher than 50V rms, 71V peak, or dc and for reinforced-insulation-level applications, the DTI (distance through insulation) must be at least 0.4 mm (Reference 2). The DTI is the internal-clearance distance between conductors inside an insulation device, such as that between the LED and the detector inside an optocoupler or optoisolator (Figure 3). To illustrate the typical specification requirements for medical equipment, Table 1 summarizes IEC 60601-1. Table 2 shows specifications of optocouplers that meet the IEC 60601 requirements for insulation. The Type 1 requirement targets devices operating at less than 70V, which require only basic insulation, and the Type 2 re-

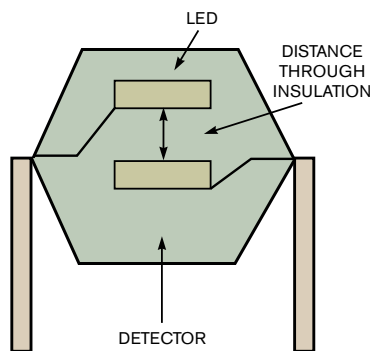

Figure 3 The distance through insulation is the internal-clearance distance between conductors in an insulation device.

TABLE 1 IEC 60601-1 SAFETY-STANDARD REQUIREMENTS

Working voltage ¹ (V _{DC})	Working voltage ¹ (V rms)	Insulation type	Creepage (mm)	Clearance (mm)	Distance through insulation ³ (mm)	Test voltage (V rms for 1 minute)
17	12	Basic ²	1.7	0.8		500
		Reinforced ²	3.4	1.6		800
34	30	Basic	2	1		500
		Reinforced	4	2		800
85	60	Basic	2.3	1.2		765
		Reinforced	4.6	2.4	0.4	1224
177	125	Basic	3	1.6		1000
		Reinforced	6	3.2	0.4	1733
354	250	Basic	4	2.5		1494
		Reinforced	8	5	0.4	2390
566	400	Basic	6	3.5		1864
		Reinforced	12	7	0.4	2982
707	500	Basic	8	4.5		2060
		Reinforced	16	9	0.4	3000
934	660	Basic	10.5	6		2343
		Reinforced	21	12	0.4	3000
1061	750	Basic	12	6.5		2508
		Reinforced	24	13	0.4	3000
1414	1000	Basic	16	9		2868
		Reinforced	32	18	0.4	3000

¹ Working voltage is the voltage to which the relevant insulation is subjected in normal use and rated supply voltage, whichever is greater.

² Class 1 equipment uses basic insulation; Class 2 equipment uses reinforced insulation.

³ The IEC 60601-1, third edition only recently instituted the DTI requirements for medical equipment, and they are identical to the DTI requirements from IEC 60950 (information-technology equipment).

quirement targets equipment that operates at voltages greater than 70V and thus requires reinforced insulation or a similar level of protection.

To meet EMC requirements in IEC 60601-1-2, medical devices must be immune to ESD (electrostatic discharge), RFI (radio-frequency interference) from nearby transmitters and other sources, and power disturbances that cause device malfunctions (Table 3). In addition to these requirements, the device's own emissions, through either conduction or radiation, may interfere with licensed communications sources or other equipment and thus should be minimal (Table 4). The devices must have ESD protection as high as 8 kV through air and 6 kV on contact. They must be immune at frequencies of 80 MHz to 2.5 GHz and 3V/m of RF electromagnetic force for non-life-supporting equipment and 10V/m for life-supporting equipment. These tests are essential performance criteria, in that they cannot have any component failures, changes in programmable parameters, resetting to factory defaults, changes of operating modes, or false alarm. Properly designed optocouplers are more immune to EMI than are

TABLE 2 IEC 60601-1-COMPLIANT INSULATION

	Type 1 requirements	Type 2 requirements	Example of optocouplers meeting Type 1 ¹	Example of optocouplers meeting Type 2 ²
Interface type	Less than 70V dc	More than 70V dc	Less than 70V dc	More than 70V
Insulation type	Basic	Double	Reinforced	Reinforced
Creepage (over-surface spacing)	4 mm	8 mm	4 mm or more	10 mm
External clearance (through-air spacing)	2.5 mm	5 mm	4 mm or more	9.6 mm
Distance through isolation (DTI)	NA	0.4 mm	0.08 mm or more	1 mm
Dielectric-strength level	1.5 kV	4 kV	3.75 kV or more	5 kV
Standard required	UL 1577 and IEC 60747-5	UL 1577 and IEC 60747-5	UL 1577 and IEC 60747-5	UL 1577 and IEC 60747-5
Example	Patient-acquisition module	Electrocardiograph device	Patient-acquisition module	Electrocardiograph device

Reproduced with permission of Gary Powalisz, GE Healthcare.

¹ Example: Avago Technologies HCPL-xxxx (HCPL-0723), ACPL-xxxL series.

² Example: Avago Technologies HCNWxxx (HCNW2611) series. Certain Avago Technologies optocouplers (wide-body-package series: HCNWxxx as well as DIP-8 package with option -020) offer a minimum isolation voltage of 5 kV rms/1 minute per UL 1577 and CSA component acceptance notice No. 5.

TABLE 3 IEC 60601-1-2 IMMUNITY REQUIREMENTS

Immunity test	IEC 60601 test level
Electrostatic discharge (ESD) IEC 61000-4-2	±6 kV contact ±8 kV air
Electrical fast transient/burst IEC 61000-4-4	±2 kV for power-supply lines ±1 kV for I/O lines
Surge IEC 61000-4-5	±1 kV lines to lines ±2 kV lines to lines
Voltage dips, short interruptions, and voltage variations on power-supply-input lines IEC 61000-4-11	Less than 5% U_r (greater than 95% dip in U_r) for 0.5 cycle 40% U_r (60% dip in U_r) for five cycles 70% U_r (30% dip in U_r) for 25 cycles Less than 5% U_r (greater than 95% dip in U_r) for 5 sec
Power frequency (50/60 Hz) magnetic field IEC 61000-4-8	3A/m

NOTE: U_r is the ac-mains voltage before application of the test level.

TABLE 4 IEC 60601-1-2 EMI REQUIREMENTS

Emissions test	Guidance
RF emissions CISPR 11	To measure the electromagnetic energy that is generated internally for it to perform its intended function that may interfere with any nearby equipment.
Conducted emissions CISPR 11	To measure the effects of emissions conducted onto ac-power lines.
Harmonic emissions/ flicker emissions IEC 61000-3-3	To measure the harmonic frequency injected into the public mains network for equipment and systems with a rated input current as high as 16A per phase and that are intended to be connected to it.
Voltage fluctuations/ flicker emissions IEC 61000-3-3	To measure the emissions, fluctuations, and flicker injected into the public mains network for equipment and systems with a rated input current as high as 16A per phase and that are intended to be connected to it.

other isolation devices, such as transformers, because optocouplers transmit signals through optical radiation between the LED light source and the photodiode. Tests on optocouplers have demonstrated their ability to withstand ESD voltage as high as 11 kV (Reference 1). Optocouplers are effective in passing the intended differential-mode signals and blocking the unintended common-mode currents and resulting ground-

offset voltage that can result from ground-loop currents.

In summary, available optocouplers clearly meet the general medical-safety requirement that IEC 60601-1 defines. In addition, optocouplers provide excellent EMI and emit no electromagnetic waves, which is now an important measure for medical-equipment certification. **EDN**

REFERENCES

- Seah Eng Lee, Jeremy, Alexander Jaus, Patrick Sullivan, and Chua Teck Bee, "Building a Safe and Robust Industrial System with Agilent's Optocouplers," White Paper, Agilent Technologies Semiconductor Products Group Isolation Products Division, Nov 17, 2005, <http://cp.literature.agilent.com/litweb/pdf/5989-1774EN.pdf>.
- IEC 60601-1, "General Requirements for Basic Safety and Essential Performance," International Electrotechnical Commission, www.iec.ch.
- IEC 60601-1-2, "International Standard for Medical Equipment," International Electrotechnical Commission, www.iec.ch.
- Powalisz, Gary, "Testing Medical Devices," *EE Evaluation Engineering*, December 2005.
- "Avago Technologies Regulatory Guide to Isolation Circuits," Publication No. 5989-2937EN, April 22, 2005.

AUTHORS' BIOGRAPHIES

Yeo Siok Been is the product manager of optocouplers at Avago Technologies, where she has worked for three years. She has a master's degree in engineering from the University of Singapore. Her personal interests include jogging.

Derek Chng Peng Hui is a product manager at Avago Technologies, where he has worked for three years. He is responsible for market development for optocoupler applications. He has a bachelor's degree in electrical engineering. His personal interests include Internet research, swimming, and going to the gym.

Jamshed Namdar Khan is an application engineer at Avago Technologies, where he has worked for 23 years. He is responsible for optocoupler products in North America and South America. He has a bachelor's degree in electrical engineering from the University of California—Berkeley. His personal interests include tennis and golf.